

103-H7123-5010.B

Dimensions (Unit:mm)

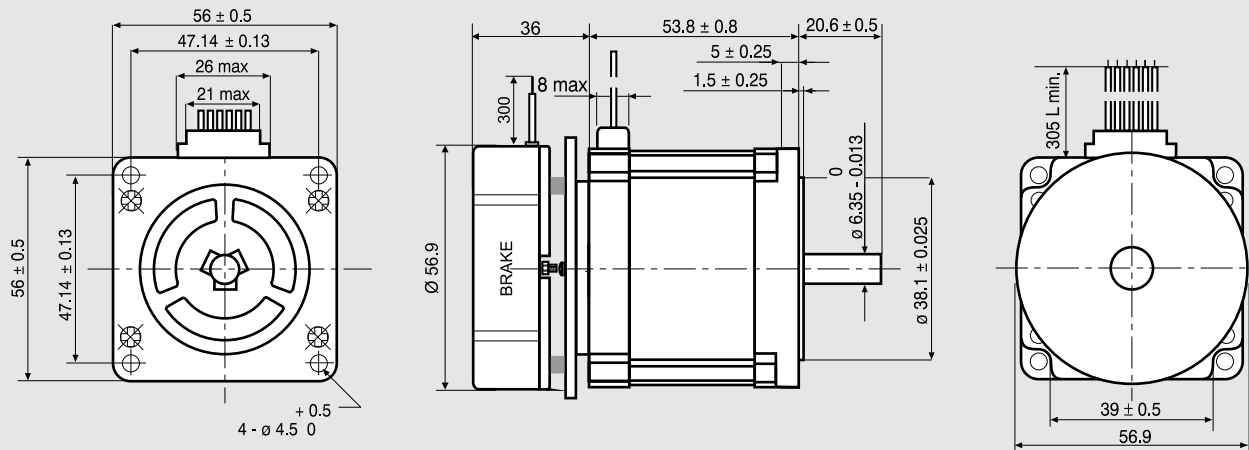

SANYO DENKI MOTOR FEATURES

MODEL	103-H7123-5010.B	
SANYO DENKI MOTOR CODE	103-H7123-5010	
BASIC STEP ANGLE	1.8° ± 0.09°	
BIPOLAR PARALLEL CURRENT	(Amp)	2.0
UNIPOLAR PARALLEL CURRENT	(Amp)	2.0
RESISTANCE	(Ohm)	0.8
INDUCTANCE	(mH)	3.8
BIPOLAR HOLDING TORQUE	(Ncm)	85
UNIPOLAR HOLDING TORQUE	(Ncm)	85
ROTOR INERTIA	(Kg ^m × 10 ⁻⁷)	210
THEORETICAL ACCELERATION	(rad × sec. ⁻²)	38500
BACK E.M.F.	(V/Krpm)	31
MASS	(Kg)	1.15
LEADS CODE	V	

R.T.A. - s.r.l. PAVIA (ITALY) SANYO DENKI CO.,Ltd (JAPAN)

BRAKE FEATURES

STATIC TORQUE	(Nm)	3.3
DUTY CYCLE		50% max.
VOLTAGE	(Volt)	24 VDC
POWER	(W)	11
RELEASE TIME	(ms)	300

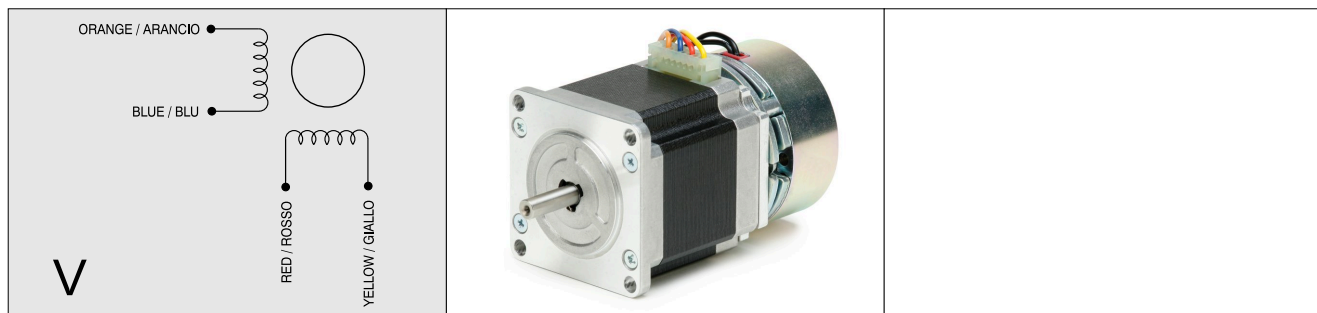

Ed. 1 Allegato EIMC - 10 - 14



CAUTION

Use for safety related functions is forbidden (EN 60204-1). Moreover, when the application arrangement is in such way that a motor fault or failure could generate a risk for property or human life, external independent safety protection system must be provided in the machine.



R.T.A. s.r.l.
Via E. Mattei - Fraz. Divisa
27020 MARCIGNAGO (PV) ITALY
Tel. +39.0382.929.855 - Fax +39.0382.929.150
www.rta.it

R.T.A. Deutschland GmbH
Bublitzer Straße 34
40599 DÜSSELDORF (Germany)
Tel. +49.211.749.668.60 - Fax +49.211.749.668.66
www.rta-deutschland.de

R.T.A. IBERICA-Motion Control Systems S.L.
C/Generalitat 22, 1° 3°
08850 GAVA - BARCELONA (Spain)
Tel. +34.936.388.805 - Fax +34.936.334.595
www.rta-iberica.es