

SG-P12-040-025-19-HH-52XX-00000

PLANETARY GEARBOXES

SG 040

$i=025$

$\varphi < 19'$

MADE IN ITALY

IP64

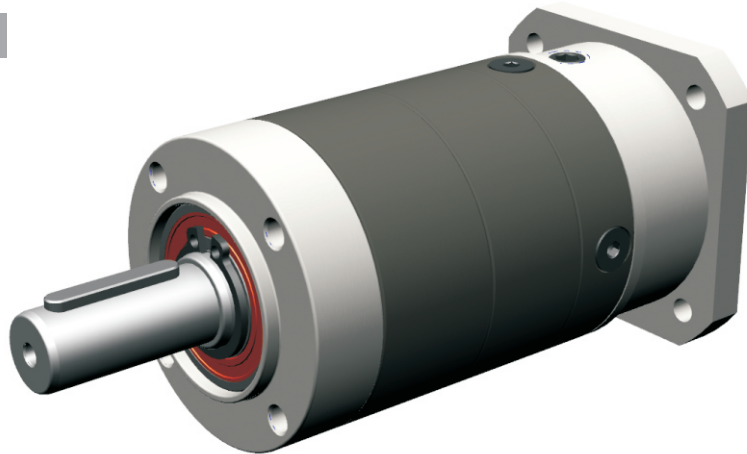

Dimensions (Units:mm)

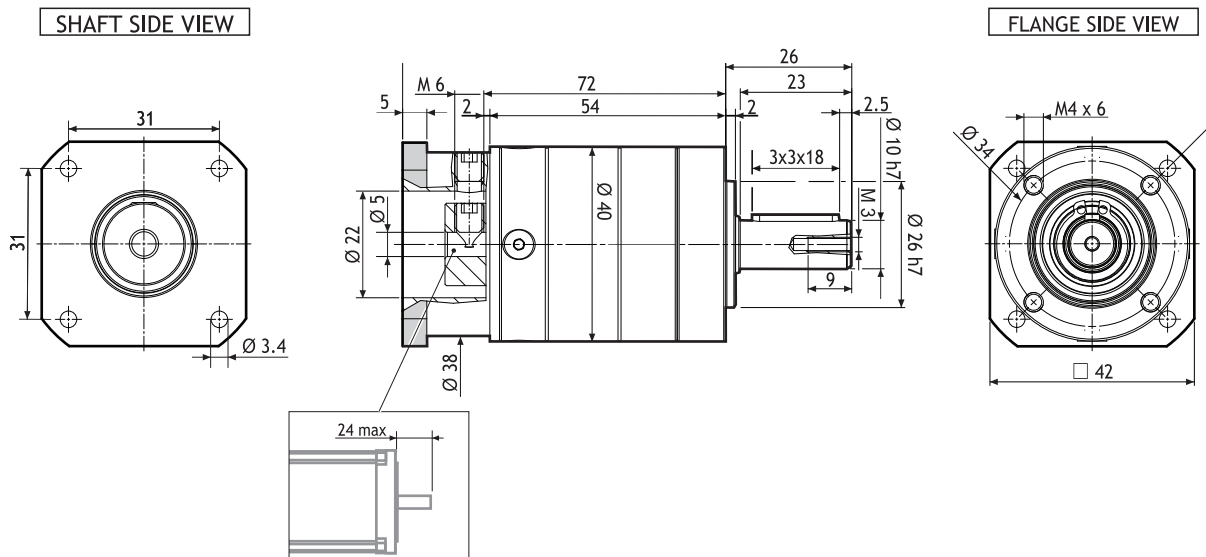

MODEL	Rated output torque [Nm]	Maximum acceleration output torque [Nm]	Emergency step output torque [Nm]	Backlash [arcmin]	Nominal input speed [min ⁻¹]	Maximum momentary input speed [min ⁻¹]	Torsional stiffness [Nm/arcmin]	Maximum radial force applying on output shaft [N]	Maximum axial force applying on output shaft [N]	Gear efficiency [%]	Gear moment of inertia [Kg·m ²]
SG-P12-040-025-19-HH-52XX-00000	12	18	30	<19'	5000	8000	0.8	220	200	97	1.5x10 ⁻⁶

Suggested motors

	103-H5205 SERIES 	103-H5208 SERIES 	103-H5210 SERIES
MOUNTING OPERATION MODE: ■ Tightening torque M=5 Nm	■ Locking bolt M4	■ R.T.A. Quality Control	