



RENOIR

MULTI AXIS MOTION CONTROLLER



1, 2 or 3 axis control.

Linear & circular interpolation.

Standard ISO G-Code language.

Suitable for stepper or servo motors.

Stand alone or computer operation.

Optional CAD file DXF & HPGL conversion.

Programs downloaded from PC.

Compatible with most stepper drives.

Encoder feedback and tracking available.

Programmable speed changes 'on the fly'.

The S & H RENOIR range are CNC multi axis controllers for automatically controlling machines using stepper or servo motors. They are designed for synchronised motion where two or more axes are run simultaneously. Wiring is reduced by included ESTOP, RESET, STOP and START switches on the panel.

Motion programs are written in ISO (G-Code) which is easy to use. The "BACH" PC based software allows operators to write, edit and verify motion programs before they are downloaded to the RENOIR via the RS232 port. USB to RS232 converters are also available.

Programs can be stored in the controller and executed as required. The controller can be used independently of a PC as programs are stored in a non volatile memory. Typical applications are XYZ profiling tables, pick & place, automatic welding, engraving, packaging machines, glueing & painting.

The RENOIR also has a keypad and display allowing stored programs can be selected and run without external switches. This also allows operators to adjust variables (eg. Speed, distance and number of cycles) which can be read by the program.

SPECIFICATIONS

POWER SUPPLY REQUIREMENTS

24 VDC @ 6W

ENCLOSURE

310mm x 237.5mm (panel) X 66mm

WEIGHT

3.4kg

OPERATING TEMPERATURE

0 to 45° C

DIGITAL INPUTS

16 off, +12 to +35 VDC

opto isolated

(some required for limit+, limit- and datum inputs)

DIGITAL OUTPUTS

8 off, +12 to +35 VDC @ 300mA

opto isolated

SERIAL PROTOCOL

9600 baud, 8 data bits, ODD parity, 1 stop bit

STEPPER DRIVE SIGNALS

Step, direction, drive enable, drive fault

100kHz max, 15 bit resolution

NPN current sink or 5V TTL

SERVO DRIVE SIGNALS

Velocity, direction, drive enable, drive fault

± 10V, 12 bit resolution

ENCODER INPUTS

5V differential

Maximum 250kHz

CONNECTORS

(on rear panel)

Drives: D9 male

Encoders: D9 female

Inputs/Outputs: D37 female

RS232: D9 male

CAN BUS: D9 male

Analog input: D9 female

PROGRAM MEMORY SIZE

150000 characters stored in RENOIR

HARDWARE FEATURES

Number of Axes

1, 2 or 3 axes. The 3rd. Axis must be stepper.

Motors

Stepper motors: step, direction and enable signals

Servo motors: $\pm 10V$ velocity command and encoder feedback or step and direction signals (like steppers)

Stepper Drive Signals

NPN current sink outputs or 5V voltage sourcing outputs. The outputs are step, direction and drive enable.

Stepper drive compatibility

Most step & direction drives including the RTA BSD, CSD, NDC, PLUS, X-PLUS and X-MIND drives.

Position Control

Stepper motors: open loop or closed loop with encoder.

Servo motors: closed loop

Motor speed

Depends on drive resolution. Maximum output frequency 100kHz.

Digital inputs

16 digital inputs, optically isolated, 24 VDC (it may be the same as the 24 VDC supply for the RENOIR). Inputs can be read by a motion program. Nine of these inputs are dedicated to limit and datum switches for all the axes.

Digital outputs

8 digital outputs, optically isolated, 24VDC @ 300mA.
Controllable by motion program.

Ramping

Linear, parabolic and "S" curve for acceleration and deceleration.

Limit & Datum inputs

Limit+, Limit- and datum for all 3 axes.

Interpolation

Linear: XY, XZ, YZ and XYZ

Circular: XY, XZ and YZ planes

Tangential Control

Optional for tangential knife control, tangential to XY gradient.

Time delays

G04 command. 0.01sec to 9999.99 seconds.

Continuous Execution

Speed can be constant with joined paths.

Stops tool burning workpiece at join points.

On the fly velocity change

Speed can be changed while running without stopping motor.

P.L.C.

PLC program in ladder logic can be run in parallel with motion program. This saves extra cost of a PLC and programming.

Programming language

ISO G-Code, familiar to most CNC machine operators.

Precision

Programmable to 6 decimal places but user can define lower resolution to make programming easier.

Protection

Password protection on the RENOIR panel preventing unauthorised operation of machine.

Parameters

Keypad allows operator entry and adjustment of upto 20 parameters that are read by the program (eg. speeds, positions, number of cycles) These are stored after power cycle.

Analog inputs

Upto 6 analog inputs, 0-5V, 10 bit and a +5V excitation for potentiometers and sensors.

Analog outputs

Upto 2 analog outputs, $\pm 10V$, 12bit

Only available with stepper versions of GOYA

Housing

High density plastic 310mm x 237.5mm x 66mm (depth).

Probe

Motor can be run at a constant speed using G06 command and stop when a probe is hit. Position can then be read by the RENOIR.

Units

Programs are written using user defined engineering units, not steps, Hz or motor revs.

CAM function

Runs a motor at a defined velocity profile according to a speed/distance lookup table

Wait

Using G66 command, motion programs can be made to WAIT until a specific input is switched ON or OFF. This can be used to delay a program until a machine is ready for the next stage.

3D motion

The RENOIR can control motors in 3 dimensional space but is not intended for 3D sculpturing. 3D paths can be generated by linear interpolation using small XYZ segments.

Encoder tracking

Programs can track encoder position or speed which can be read from the motion program. Maximum encoder frequency 250kHz.

Tool radius offset

Optional G40, G41 and G42 commands for kerf compensation on straight paths and arcs. Only possible when running from a computer.

Master/Slave

Runs a motor or motors at a defined ratio of speed of another machine, sensed by an encoder.

Special functions

Optional PWM output for lasers, firmware for glueing applications, CAN-BUS and tangential control with knife angle.

PROGRAMMING FEATURES

Programming Language

The motion language is 'ISO' of G-Code which is used on CNC machine tools. Machine operators will be familiar with this, eliminating the need for computer programmers. The programs are basic text files which can be read, edited and printed using a text editor.

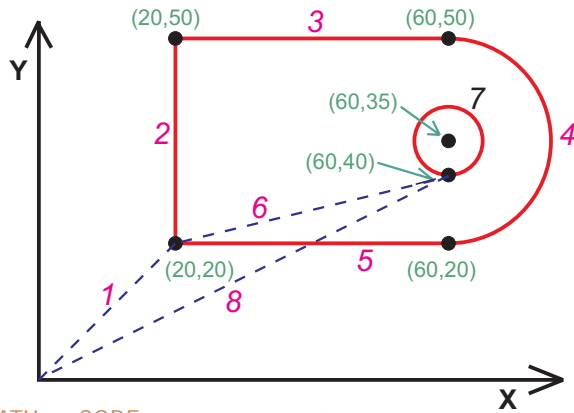

PATH	CODE	DESCRIPTION
1	G00 X20 Y20 F1000 G00 Z20 F500 G68 P1	Goto (20,20) rapidly, speed 1000mm/min Lower Z to 20mm at 500 mm/min Turn output 1 ON
2	G01 X20 Y50 F300	Goto (20,50), speed 300mm/min
3	G01 X60 Y50	Goto (60,50) at same speed
4	G02 X60 Y20 I60 J35	Clockwise arc ending (60,20), centre (60,35)
5	G01 X20 Y20 G00 Z0 F500	Goto point (20,20), same speed Raise Z axis to 0mm at 500 mm/min
6	G00 X60 Y40 F1000 G00 Z20 F500 G68 P1	Goto (60,40) rapidly, speed 1000 mm/min Lower Z to 20mm Turn output 1 ON
7	G02 X60 Y40 I60 J35 F300 G68 P1 G00 Z0 F500	Arc ending at (60,40), centre (60,35) Turn output 1 OFF Raise Z to 0mm at 500 mm/min
8	G00 X0 Y0 F1000	Goto datum 1000 at mm/min

BACH software

The S&H BACH Lite software allows loading of settings to the RUBENS, manual control and terminal mode (typing commands and sending to the RUBENS by hitting return key). It is supplied free with the RUBENS controller. The full version of BACH will allow editing of and downloading motion programs to the RUBENS and uploading from RUBENS to a computer. This version requires a dongle at extra cost. BACH will run on existing Windows XP, Windows 7 and earlier versions of Windows. Motion programs can be run from a computer or from the RUBENS by selecting them from the keypad.

If the BACH software is not suited to your application, it is possible for you to write your own software.

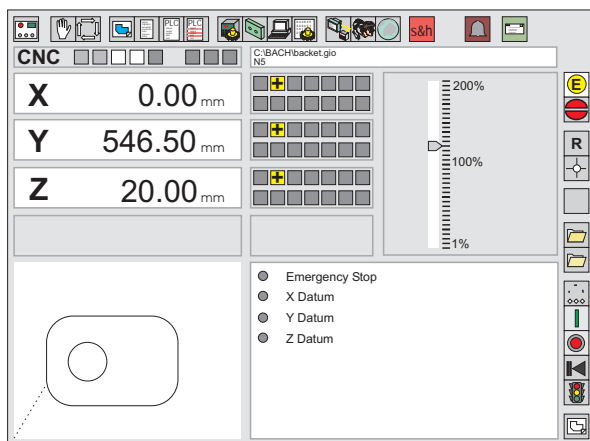

Subroutines

When run in stand alone mode, programs can support subroutines to reduce program size (nested to 8 levels).

Settings

A file containing all machine settings for the RUBENS can be extracted and saved for backup purposes. This is also an ASCII text file and consists of motor speeds, ramps, scaling factors and input functions.

Loops

GOYA programs can support both conditional and unconditional looping to reduce program size.

Variable management

The RENOIR can perform mathematical operations on variables. Operators are + - * / ^ and square root. Variables can be derived from parameters entered on the keypad or analog inputs.

CAD files

For complex shapes consisting of curves, arcs, lines and points, writing programs can be difficult. The BACH program has an optional DXF and HPGL file conversion function. BACH will automatically insert code at beginning and end of a program and before and after each path.

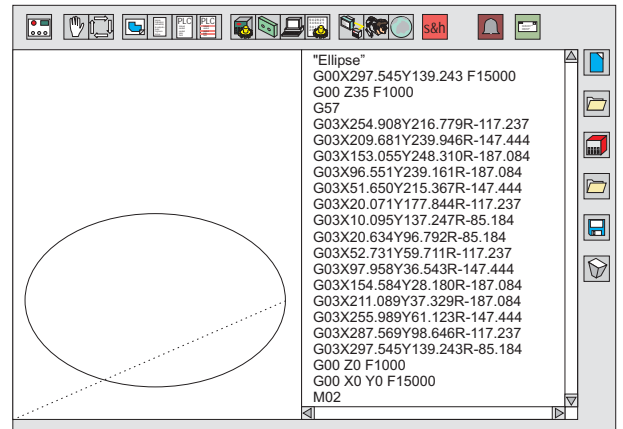

Program size reduction

CAD files can sometimes produce programs with too many small line segments, taking up valuable memory space in the RUBENS. BACH has an optional reduction function that can replace numerous program lines of linear segments to a low number of arcs.

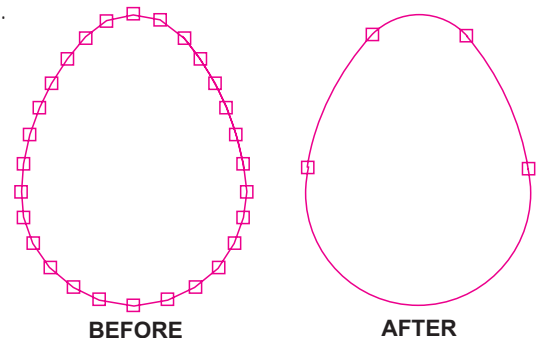

No mouse operation

Computer mice don't survive well in factory environments. BACH will allow operation without a mouse by utilising F10 and arrow keys on a computer keyboard.

Teach Mode

Some applications require a motion program based on points generated by manual movement of motors. This function allows an operator to generate program lines by moving motors to required positions and clicking a mouse to generate the line of code.

SUPPORTED COMMANDS

G00	Rapid move (no interpolation)	G53	Origin of axes at this point
G01	Move with interpolation	G54	Origin of axes at this point (software set)
G02	Clockwise circular Interpolation	G55	Save current origin
G03	Anticlockwise circular Interpolation	G56	Restore origin set by G55
G04	Dwell (time delay)	G57	Activate continuous velocity
G06	Run axis continuously	G58	Deactivate continuous velocity
G16	Define plane of circular interpolation	G61	Activate accurate stop
G17	Select XY plane for circular interpolation	G62	Deactivate accurate stop
G18	Select XZ plane for circular interpolation	G63	Activate 'don't wait for end of movement'
G19	Select ZY plane for circular interpolation	G64	Deactivate 'don't wait for end of movement'
G20	Unconditional jump	G65	Wait for input to go low before proceeding
G21	Jump if flag TRUE	G66	Wait for input to go high before proceeding
G22	Jump if flag FALSE	G67	Switch output OFF
G25	Define minimum limits	G68	Switch output ON
G26	Define maximum limits	G69	Assign state of flag
G27	Cancel work limits	G70	Units in inches
G30	Recall subroutine	G71	Units in millimetres
G31	Recall subroutine if flag TRUE	G80	Enable/Disable cam table
G32	Recall subroutine if flag FALSE	G81	Define DISENGAGE cam positions
G50	Cancel displacement of origin	G82	Define automatic cam table
G51	Seek Datum switch	G83	Define cam factor
G52	Displacement of origin	G84	Define cam velocity variations
G90	Activate absolute coordinates	G94	Deactivate tangential tool guide
G91	Activate relative coordinates		

TYPICAL SCHEMATIC

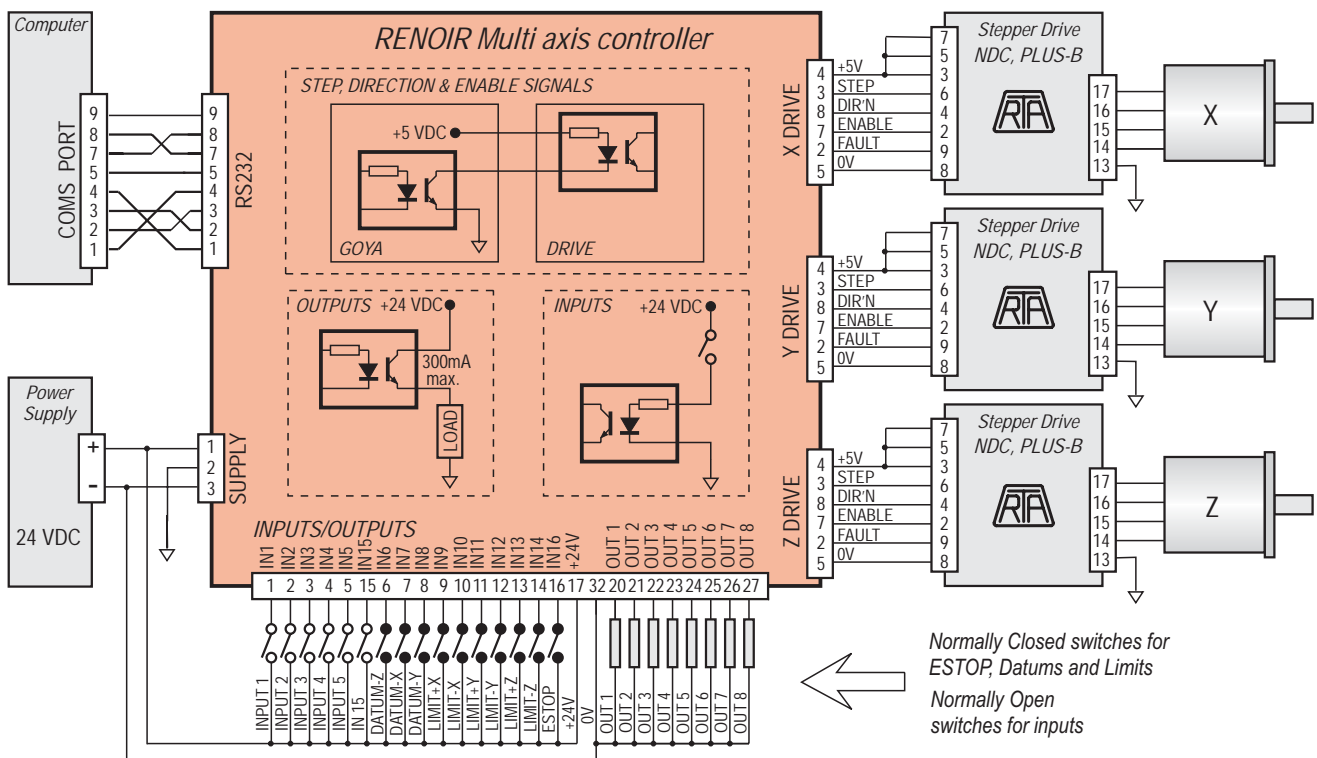

Continuous development may necessitate changes in specifications without notice.

Motors, drives, belts & pulleys and gearheads also available.

AUTOMATED MOTION SYSTEMS PTY.LTD.

MAILING ADDRESS:

P.O.BOX 1240
WANGARA DC
W.A. 6947

PHONE: (08) 9309 1896

EMAIL: sales@automotsys.com.au

INTERNET: <http://www.automotsys.com.au>

OFFICE ADDRESS:

UNIT2, 7 BARETTA RD.
WANGARA, PERTH
WESTERN AUSTRALIA