

CLUTCH BRAKE (hexagonal housing)

TYPE 54



SG Transmission

Electromagnetic Clutch & Brake Solutions

SG Transmission, 20 Longfield Road, South Church Enterprise Park, Bishop Auckland, County Durham, UK, DL14 6XB
Tel: +44 (0)1388 770 360 Fax: +44 (0)1388 779 197 sales@sgtransmission.com www.sgtransmission.com

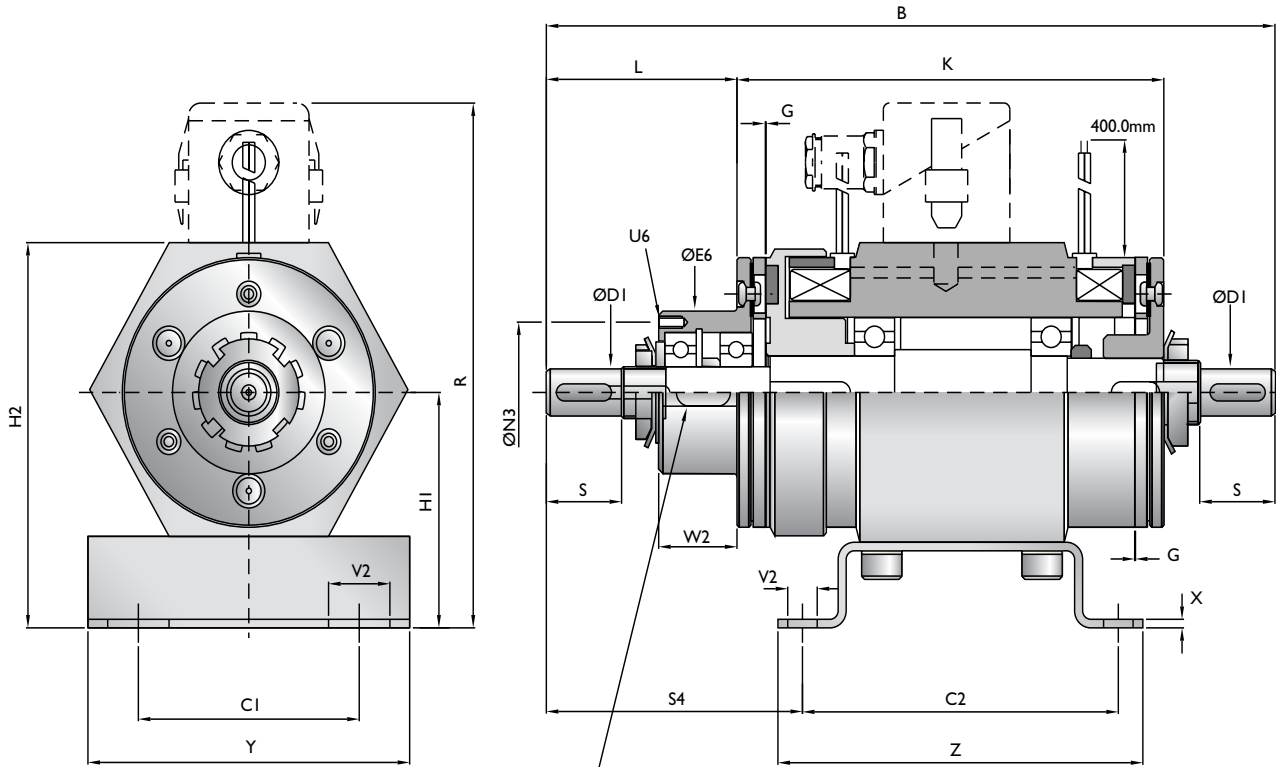

Optional B.S. Keyseat, Flat or Circlip + Key, on request

Size	Trq TS (Nm)	Max P20 (w)	B	C1	C2	D1 j6	E6 k6	G	H1	H2	K	L	N3	R	S	S4	U6	V1	V2	W2	X	Y	Z	Design NO.
03	1.2	8	110	36	-	6	18	0.15	30	55	70	24	-	-	12	62	-	-	M6	9	-	51	15	0301
05	3	10	144	50	48	7	30	0.20	40	70	90	30	24	-	18	53.5	3xM3	6.5	4.5	12	1.5	65	60	0501
06	8	16	195	55	75	11	38	0.20	55	90	107	54	33	133.5	25	70	3xM4	14	7	19.5	2	80	90	0601

SEE SECOND DATA SHEET FOR SIZES 08, 10, 12

Keyways to B.S. 4235 • Shaft centre-holes to DIN 332 • Insulation Class B

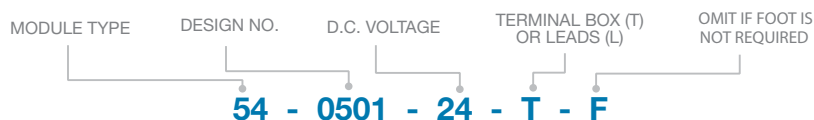

MILITARY



MEDICAL



MATERIAL HANDLING



ENERGY



SECURITY

COMBINED CLUTCH BRAKE PACKAGES

TYPE 54

SG Transmission, 20 Longfield Road, South Church Enterprise Park, Bishop Auckland, County Durham, UK, DL14 6XB
Tel: +44 (0)1388 770 360 Fax: +44 (0)1388 779 197 sales@sgtransmission.com www.sgtransmission.com



SG Transmission

Electromagnetic Clutch & Brake Solutions

SG Transmission type 54 combined clutch and brake packages are normally used in belt or chain driven applications where the rotary motion is derived from a remote location or from a co-axially coupled motor.

They are used whenever the prime mover is required to run continuously and the unit which it is driving is to have a controlled "stop-start" action. Allowing an electric motor to run and controlling its output with a combined clutch brake unit reduces the power consumption of the system considerably. These units are precisely manufactured with a positive "stop-start" action they can be controlled with relatively simple solid state electronics to give accurate repeatable positioning.



Advantages

Easy installation

The unit comes ready assembled in a neat package that can be foot mounted or designed to incorporate a mounting flange to accommodate specified requirements.

Tough construction

Type 54 units are robustly designed and use deep groove ball bearings on the input and output sides of the unit. They can be mounted in any angular plane.

Wear adjustment

Independent armature plates are used, therefore any wear caused during the switching from clutch to brake can be independently corrected.

Safety

Clutch and brake linings are hard wearing and do not contain asbestos.

Maintenance

SG Transmission clutch brake units are virtually maintenance free. However they are sometimes used to control large inertia loads with relatively high switching frequencies. In these cases the air-gaps between the clutch / brake face and armature plate should be periodically checked and adjusted as necessary.

Customisation

We specialise in customising our combined modules to meet your exact requirements, so alternative configurations may be available on request.

SG Transmission also offers a range of double clutch combined modules, with hexagonal and extruded housing.

Please contact us, or refer to our website for full details.

Adjustments

1. With clutch coil de-energised measure the air-gap, in three places, between the clutch face and armature plate using a feeler gauge.
2. If the air-gap exceeds the nominal dimension ('g' on the type 54 data sheet) by more than 0.20mm an adjustment maybe necessary.
3. Adjustment is relatively simple. Secure the shaft to prevent rotation during the adjustment, unlock the clutch locknut and rotate to move the armature and hub assembly along the shaft thereby adjusting the air-gap of the clutch. The locknut is used in conjunction with a lockwasher. The lockwasher has a tab which must be released before adjustment is attempted.
4. After resetting the air-gap, secure the locknut and energise / de-energise the clutch coil several times to ensure correct operation.
5. Re-check the air-gap (as in 1.) and repeat the procedure for the brake (using the nominal dimension 'g' from the data sheets to follow.

