

# SM 2861-5025.B

## Dimensions (Unit:mm)

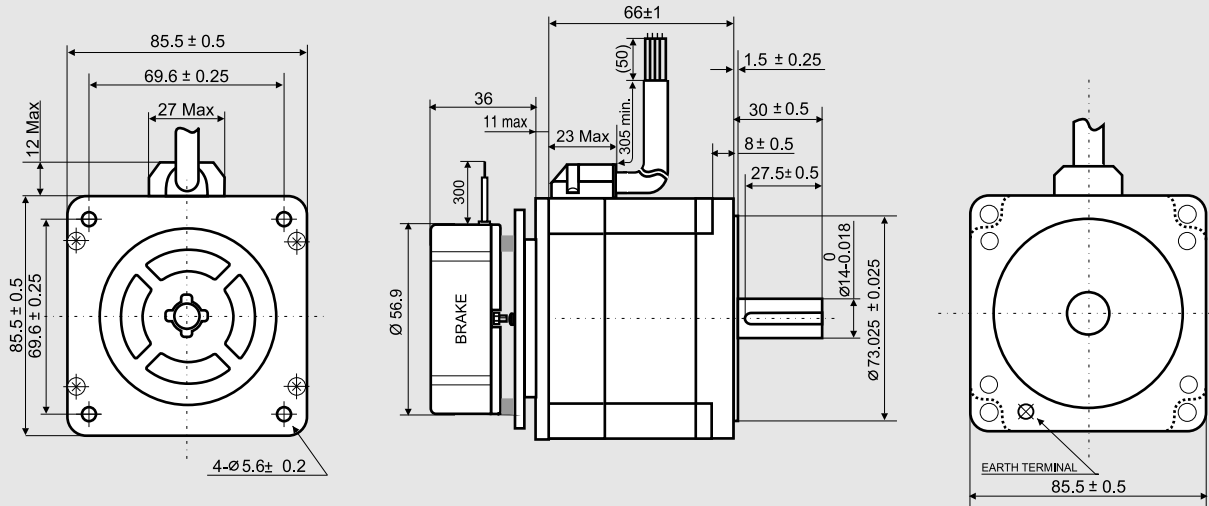

## SANYO DENKI MOTOR FEATURES

MODEL	SM 2861-5025.B	
SANYO DENKI MOTOR CODE	SM 2861-5025	
BASIC STEP ANGLE	1.8° ± 0.09°	
BIPOLAR PARALLEL CURRENT	(Amp)	2.0
RESISTANCE	(Ohm)	2.2
INDUCTANCE	(mH)	15
BIPOLAR HOLDING TORQUE	(Ncm)	360
ROTOR INERTIA	(Kg·m <sup>2</sup> × 10 <sup>-7</sup> )	1480
THEORETICAL ACCELERATION	(rad × sec. <sup>-2</sup> )	24300
BACK E.M.F.	(V/Krpm)	180
MASS	(Kg)	2.2
INTERNATIONAL STANDARDS	UL, CSA	
INSULATION VOLTAGE	(V)	250 VAC (350 VDC)
PROTECTION DEGREE - INSULATION CLASS	IP43 - F	
LEADS CODE	V	

R.T.A. - s.r.l. PAVIA (ITALY) SANYO DENKI CO., Ltd (JAPAN)

## BRAKE FEATURES

STATIC TORQUE	(Nm)	3.3
DUTY CYCLE		50% max.
VOLTAGE	(Volt)	24 VDC
POWER	(W)	11
RELEASE TIME	(ms)	300



Ed. 1 Allegato EIMC - 10 - 14



**CAUTION**

Use for safety related functions is forbidden (EN 60204-1). Moreover, when the application arrangement is in such way that a motor fault or failure could generate a risk for property or human life, external independent safety protection system must be provided in the machine.



R.T.A. s.r.l.  
Via E. Mattei - Fraz. Divisa  
27020 MARCIGNAGO (PV) ITALY  
Tel. +39.0382.929.855 - Fax +39.0382.929.150  
www.rta.it

R.T.A. Deutschland GmbH  
Bublitzer Straße 34  
40599 DÜSSELDORF (Germany)  
Tel. +49.211.749.668.60 - Fax +49.211.749.668.66  
www.rta-deutschland.de

R.T.A. IBERICA-Motion Control Systems S.L.  
C/Generalitat 22, 1° 3°  
08850 GAVA - BARCELONA (Spain)  
Tel. +34.936.388.805 - Fax +34.936.334.595  
www.rta-iberica.es